

REVISIONS			
SYMBOL	DESCRIPTION	DATE	APPROVAL
L	Revised per RN A-203.	2/23/16	JS
K	Revised per RN A-191	12/29/14	JS
J	Revised per RN A-183	4/25/13	JS
I	Revised per RN A-170.	7/15/11	JS
H	Revised per RN A-151.	1/8/09	JS
G	Document revised.	5/12/95	JHB

**SHEET REVISION STATUS**

SH	1	2	3	4	5	6	7	8	9	10	11	12	13	14	15	16	17	18	19	20
REV	L	L	L	L	L	L	L	L	L	L	L	L	L	L	L	L	L	L		
SH	21	22	23	24	25	26	27	28	29	30	31	32	33	34	35	36	37	38	39	40
REV																				

<b>ORIGINATOR:</b> T. Perry/Unisys	<b>DATE</b> 05/22/91	<b>FSC: 5905</b>
<b>APPROVED:</b> S. Archer-Davis/Unisys	05/22/91	<b>Thermistor, (Thermally Sensitive Resistor), Insulated and Uninsulated, Negative Temperature Coefficient, Specification for</b>
<b>CODE 311 APPROVAL:</b> P. J. Jones/GSFC	06/10/91	
<b>CODE 311 SUPERVISORY APPROVAL:</b> G. P. Kramer, Jr./GSFC	06/10/91	
<b>ADDITIONAL APPROVAL:</b>		<b>S-311-P-18</b>

1. SCOPE

1.1 Scope. This specification covers the procurement requirements for thermal resistors (thermistors) with insulated or uninsulated leads. These devices are intended to be used for temperature compensation, control, and/or measurement over the specified temperature range during extended flight in space.

1.2 Goddard part number. Parts procured in complete compliance with the requirements of this specification shall be identified by a Goddard part number of the following form.

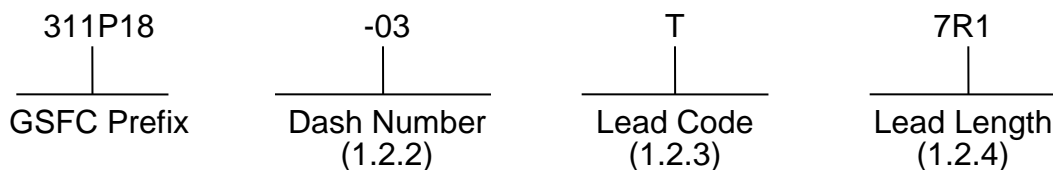

1.2.2 Dash number. The dash number identifies the zero-power resistance at +25°C and tolerance limits in accordance with Table I.

Table I. Dash numbers.

Dash No.	Zero power Resistance @ 25°C (Ω)	Tolerance Limits @ 25°C (± %R)	Operating and Storage Temperature Limits (°C)	Color Code Body/End	Tolerance Limits @ Selected Temperatures (± %R)			
					-40°C	0°C	+40°C	+70°C
01	2252	0.88	-55 to +90	Black/Yellow	2.66	1.02	0.81	0.68
02	2252	0.44	-55 to +70	Orange/Orange	1.33	0.51	0.40	0.34
03	3000	0.88	-55 to +90	Black/Green	2.66	1.02	0.81	0.68
04	3000	0.44	-55 to +70	Orange/Black	1.33	0.51	0.40	0.34
05	5000	0.88	-55 to +90	Black/Violet	2.67	1.02	0.80	0.68
06	5000	0.44	-55 to +70	Orange/Yellow	1.34	0.51	0.40	0.34
07	10000	0.81	-55 to +90	Black/Blue	2.37	0.93	0.74	0.64
08	10000	0.40	-55 to +70	Orange/Brown	2.37	0.46	0.37	0.32
09	30000	0.86	-55 to +90	Black/Gray	2.43	0.99	0.79	0.68
10	30000	0.43	-55 to +70	Orange/Red	1.21	0.49	0.40	0.34

1.2.3 Lead code. The lead material and style shall be as specified by the lead codes in Table II.

Table II. Lead codes.

Lead Code	S	N	A	T	E
Lead Style	32 AWG, tinned solid copper wire, LW(0.20)C-32-N per MIL-STD-1276	32 AWG solid nickel wire, LW(0.20)N-01-N per MIL-STD-1276	28 AWG silver coated stranded wire, ETFE per M22759/33-28-9	28 AWG silver coated stranded wire, PTFE per M22759/22-28-9	32 AWG tinned solid copper wire, LW(0.20)C-32-N per MIL-STD-1276, one lead bare, one lead insulated with PTFE tubing per MIL-I-22129, covered with heat shrinkable FEP insulation per M23053/11-105-C
Lead Length	7.6 centimeters (minimum) 100.0 centimeters (maximum)				

1.2.4 Lead length. The lead length in centimeters shall be specified by three characters consisting of either two digits and the letter R, or three digits without the letter R. Whenever the letter R is used as a decimal point, the remaining two digits are significant figures. If three digits are used without the letter R, the first two digits are significant figures, and the last digit is the number of zeroes to follow.

Examples:

7R6 = 7.6 centimeters  
76R = 76 centimeters  
101 = 100 centimeters

The lead length shall meet the dimensional limits specified in Table II.

1.2.5 Color code. Parts shall be identified by color code in accordance with Table I.

1.2.6 Performance characteristics.

1.2.6.1 Zero-power resistance. The zero-power resistance values at +25°C shall be as specified in Table I. Zero-power resistance values at temperatures over the temperature range of -80°C to +150°C are as specified in Table V.

1.2.6.2 Operating temperature. The operating temperatures shall be as follows:

- (a) Odd dash numbers: -55°C to +90°C
- (b) Even dash numbers -55°C to +70°C

1.2.6.3 Interchangeability. Each thermistor shall be interchangeable with other thermistors of the same dash number to the following accuracies over the temperature range of 0 to +70°C:

- (a) Odd dash numbers shall be  $\pm 0.2^\circ\text{C}$
- (b) Even dash numbers shall be  $\pm 0.1^\circ\text{C}$

## 2. APPLICABLE DOCUMENTS

2.1 Applicable documents. The following documents, of the issue in effect on the date of the invitation for bids or request for proposal, form a part of this specification to the extent specified herein:

### SPECIFICATIONS

MIL-I-22129            Insulation Tubing, Electrical, Polytetrafluoroethylene Resin, Nonrigid

MIL-PRF-23648        Thermistor, (Thermally Sensitive Resistor), Insulated, General Specification for

MIL-I-45208            Inspection Systems Requirements

### STANDARDS

MIL-STD-1276         Leads for Electronic Component Parts

### OTHER PUBLICATIONS

ASTM E595             Total Mass Loss and Collected Volatile Condensable Materials from Outgassing in a Vacuum Environment, Standard Test Method for

SAE AS22759/22       Wire, Electric, Fluoropolymer-Insulated, Extruded TFE, Silver-Coated High Strength Copper Alloy Conductor, 600 Volt.

SAE AS22759/33       Wire, Electrical, Fluoropolymer-Insulated, Cross-Linked Modified ETFE, Lightweight, Silver-Coated, High-Strength Copper Alloy, 200°C, 600 Volt.

SAE-AMS-DTL-23053/11    Insulation Sleeving, Electrical, Heat Shrinkable, Fluorinated Ethylene Propylene, Non-Crosslinked

2.2 Order of precedence. In the event of any conflict between the text of this specification and the references cited herein, the text of this specification shall take precedence. However, nothing in this text shall supersede applicable laws and regulations unless a specific exemption has been obtained.

2.3 Copies of documents. Copies of federal and military documents can be obtained from the Standardization Document Order Desk, 700 Robbins Avenue, Building #4-Section D, Philadelphia, PA, 19111-5094. Copies of ASTM publications are available from the American Society for Testing and Materials, 1916 Race Street, Philadelphia, PA 19103. Copies of SAE documents may be purchased from the Society of Automotive Engineers, 400 Commonwealth Drive, Warrendale, PA, 15096-0001.

### 3. REQUIREMENTS

3.1 General requirements. Requirements shall be in accordance with the latest issuance of MIL-PRF-23648 to the extent specified herein.

3.2 Qualification. Thermistors furnished to this specification shall be product which has been granted qualification approval by NASA/GSFC. Qualification approval shall be based on the following criteria.

3.2.1 Design and source approval. Prior to qualification, the manufacturer's facility shall be subjected to survey at the option of GSFC, by the Office of Flight Assurance, GSFC. Compliance with MIL-I-45208 is required. In addition, the history and detailed engineering of the specific thermistor design will be reviewed, as will the documented manufacturing and quality control procedures. Only those sources approved in the design and source approval phase shall be eligible for qualification or award of contract under this specification. Source approval and design approval do not constitute part qualification or an equivalent thereof.

3.2.2 Part qualification. Thermistor product granted qualification shall be that which has passed the qualification requirement of this specification. This requirement may be satisfied by passing the qualification inspection (see 4.4).

### 3.3 Materials.

3.3.1 Materials. Materials shall be as specified herein. However, when a definite material is not specified, a material shall be used which will enable the thermistors to meet the performance requirement of this specification. Acceptance or approval of any constituent material shall not be construed as a guaranty of the acceptance of finished product.

3.3.2 Thermal outgassing. When tested as specified in 4.7, materials must meet outgassing limits of 1.0% total mass loss (TML) maximum and 0.1% collected volatile condensable materials (CVCM) maximum.

3.4 Design and construction. Thermistors shall be of the design, construction and dimensions depicted in Figure 1.

3.5 Short time overload. When tested as specified in 4.8, the maximum allowable change in +40°C zero-power resistance shall be  $\pm 1.0\%$ .

3.6 Insulation resistance. When tested as specified in 4.9, the insulation resistance shall be not less than 100 megohms.

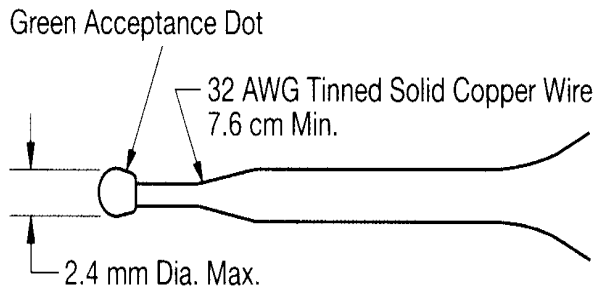

**Type S Lead Configuration**

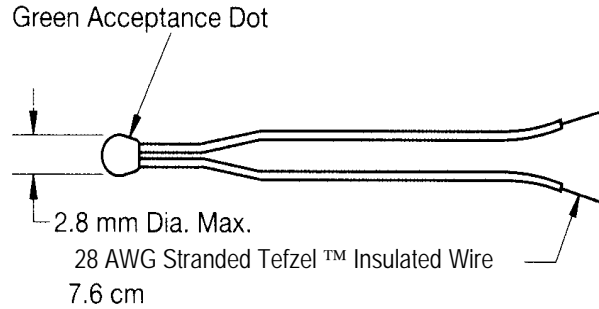

**Type A Lead Configuration**

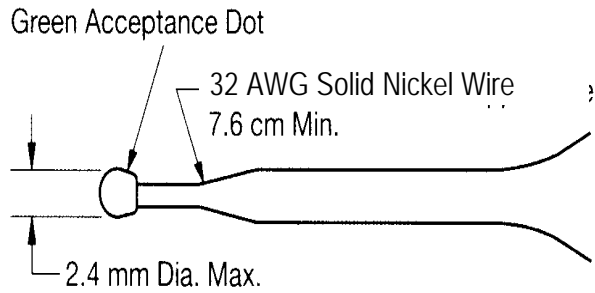

**Type N Lead Configuration**

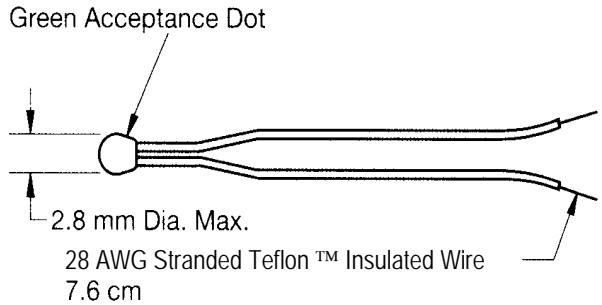

**Type T Lead Configuration**

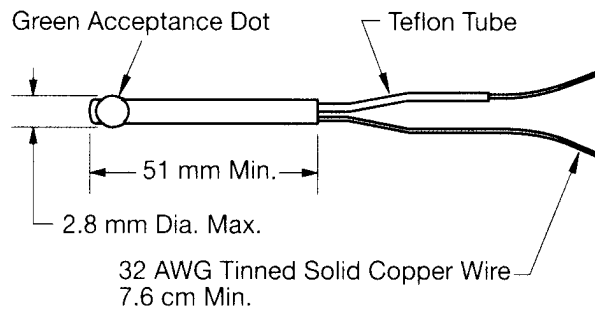

**Type E Lead Configuration**

**Figure 1. Thermistor configuration.**

- 3.7 Low temperature storage. When tested as specified in 4.10, the maximum allowable change in +40°C zero-power resistance shall be  $\pm 1.0\%$ .
- 3.8 High temperature storage. When tested as specified in 4.11, the maximum allowable change in +40°C zero-power resistance shall be  $\pm 0.5\%$ .
- 3.9 Dissipation constant. When tested as specified in 4.12, the dissipation constant shall be 1.0 milliwatts per degree Centigrade minimum in still air.

- 3.10 Thermal time constant. When tested as specified in 4.13, the thermal time constant in still air shall be 10 seconds maximum for type S lead configuration, 20 seconds maximum for types N, A, and T, and 25 seconds maximum for type E.
- 3.11 Terminal strength. When tested as specified in 4.14 with an applied pull of 2.2N (0.5 pounds), the change in +40°C zero-power resistance shall not exceed  $\pm 0.5\%$ .
- 3.12 Resistance temperature characteristic. When tested as specified in 4.15, the values obtained for each thermistor at each of the 8 temperature points indicated in Table III shall conform to the values in Table V within the tolerance limits specified in Figure 2.

Table III. Resistance-temperature characteristic test temperatures. \*

Step	Temperature (°C)	Step	Temperature (°C)
1	-55	5	+25
2	-35	6	+40
3	-15	7	+70
4	0	8	+100

\* Use only steps 4, 6, and 7 for Group A inspection. Use all steps for qualification inspection.

- 3.13 Thermal shock. When tested as specified in 4.16, the maximum allowable change in +40°C zero-power resistance shall be  $\pm 1.0\%$ .
- 3.14 Resistance to soldering heat. When tested as specified in 4.17, the maximum allowable change in +40°C zero-power resistance shall be  $\pm 0.5\%$ .
- 3.15 Moisture resistance. When tested as specified in 4.18, the maximum allowable change in +40°C zero-power resistance shall be  $\pm 5.0\%$ .
- 3.16 High temperature exposure. When tested as specified in 4.19, the maximum allowable change in +40°C zero-power resistance shall be  $\pm 1.0\%$  after 100 hours, and  $\pm 2.0\%$  after 1000 hours.
- 3.17 Vibration, high frequency. When tested as specified in 4.20, the maximum allowable change in +40°C zero-power resistance shall be  $\pm 1.0\%$ .
- 3.18 Shock, specified pulse. When tested as specified in 4.21, the maximum allowable change in +40°C zero-power resistance shall be  $\pm 1.0\%$ .
- 3.19 Immersion. When tested as specified in 4.22, the maximum allowable change in +40°C zero-power resistance shall be  $\pm 2.0\%$ .

#### 4. QUALITY ASSURANCE PROVISIONS

- 4.1 Responsibility for inspection. The manufacturer is responsible for the performance of all inspection requirements, as specified herein, using his own or any other suitable facility acceptable to Goddard Space Flight Center. Upon receipt of product, Goddard reserves the right to perform any of the inspections set forth in the specification where such inspections are deemed necessary to verify conformance to prescribed requirements.
- 4.2 Classification of inspection. Inspection requirements specified herein are classified as follows:
- a. Qualification Inspection (see 4.4)
  - b. Quality Conformance Inspection (see 4.5).
- 4.3 Inspection conditions. Unless otherwise specified herein, the thermistors shall be manufactured and tested in accordance with the quality assurance provisions of MIL-PRF-23648.
- 4.4 Qualification inspection (see 4.2). Qualification inspection shall be performed by the manufacturer on sample units produced with equipment, processes and procedures normally used in production. Qualification shall be performed per the requirements, sample sizes, and test methods specified in MIL-T-23468.
- 4.4.1 Inspection report. Qualification test data and the qualification test samples shall be submitted to the following activity:
- QPLD Administrator, Code 562  
Goddard Space Flight Center  
Greenbelt, MD 20771
- 4.5 Quality conformance inspection (see 4.2). Quality Conformance Inspection (QCI) shall be performed on all product furnished to this specification.
- 4.5.1 Inspection of product for delivery. Inspection of product for delivery shall consist of the Group A inspection per Table IV in the order shown.
- 4.5.2 Inspection marking. Thermistors successfully passing Group A inspection shall be marked with a green dot on the thermistor body.
- 4.5.3 Lot rejection. Lots having more than 10 percent total rejects, or two thermistors, whichever is greater, that are rejected due to exceeding specified resistance changes after Group A thermal shock or high temperature storage testing, shall not be furnished on the contract or purchase order. Thermistors failing zero-power resistance at any Group A test temperature shall be rejected and removed from the procurement lot but do not count towards the lot rejection percentage.



Table IV. Group A inspection.

Examination or Test (100% Inspection) (see 4.5.3)	Requirement	Method
Visual & Mechanical	3.1*, 3.3*, 3.25*, 3.27*	4.8.1*
Zero-Power Resistance	1.2.6.1	4.8.2*
Thermal Shock	3.13	4.16
High Temp. Storage	3.8	4.11
Zero Power Resistance	1.2.6.1	4.8.2*
Insulation Resistance	3.6	4.9
Resistance-Temperature Characteristics	3.12	4.15

\*Per MIL-PRF-23648

4.6 Retention of qualification.

4.6.1 Annual requalification. The manufacturer shall submit the following on an annual basis to the address listed in 4.4.1.

- (a) Summary of all orders accepted and/or shipped under the provisions of this specification.
- (b) A summary of all test results for tests performed in accordance with requirements contained in the following paragraphs of this document:

- 3.5 Short time overload
- 3.7 Low temperature storage
- 3.9 Dissipation constant
- 3.10 Thermal time constant
- 3.11 Terminal strength
- 3.14 Resistance to soldering heat
- 3.15 Moisture resistance
- 3.16 High temperature exposure
- 3.17 Vibration, high frequency
- 3.18 Shock, specified pulse
- 3.19 Immersion

At least one test result must be reported for each of the above. If none occurs during the course of the year, a special test run will be performed to comply with the provisions of this requirement.

- (c) Summaries of any life tests or other special testing performed during the previous year that is pertinent to space flight use of thermistors.
- (d) Listing of any catastrophic failures during the previous year with details on failure analysis and corrective action.

- 4.7 Thermal outgassing (see 3.3.2). Thermistors shall be tested in accordance with ASTM E595.
- 4.8 Short time overload (see 3.5). Thermistors shall be tested in accordance with para. 4.8.5 of MIL-PRF-23648.
- 4.9 Insulation resistance (see 3.6). Thermistors shall be tested in accordance with para. 4.8.6 of MIL-PRF-23648.
- 4.10 Low temperature storage (see 3.7). Thermistors shall be tested in accordance with para. 4.8.8 of MIL-PRF-23648.
- 4.11 High temperature storage (see 3.8). Thermistors shall be tested in accordance with para. 4.8.9 of MIL-PRF-23648.
- 4.12 Dissipation constant (see 3.9). Thermistors shall be tested in accordance with para. 4.8.10 of MIL-PRF-23648.
- 4.13 Thermal time constant (see 3.10). Thermistors shall be tested in accordance with para. 4.8.11 of MIL-PRF-23648.
- 4.14 Terminal strength (see 3.11). Thermistors shall be tested in accordance with para. 4.8.12 of MIL-PRF-23648.
- 4.15 Resistance-temperature characteristic. The thermistors shall be stabilized at each of the ambient temperatures listed in Table III for qualification inspection, and only at steps 4 (0°C), 6 (+40°C) and 7 (+70°C) for Group A inspection. Zero-power resistance measurements shall be made in accordance with 4.8.2 of MIL-PRF-23468 at each specified temperature, after a stabilization time equal to not less than ten times the applicable thermal time constant. Resistance shall be tabulated for each measurement.
- 4.16 Thermal shock (see 3.13). Thermistors shall be tested in accordance with para. 4.8.14 of MIL-PRF-23648.
- 4.17 Resistance to soldering heat (see 3.14). Thermistors shall be tested in accordance with para. 4.8.15 of MIL-PRF-23648 except as modified herein:
- Para. 4.6.15 (b) Special preparation of specimen: Attach a flat-jawed solid copper clip, having a mass of not less than one gram, to each thermistor lead and not more than 5 mm from the thermistor body. Pass the thermistor leads through holes approximately 2.5 mm apart in perforated epoxy-fiberglass board approximately 1.6 mm thick so that the clips rest against the top of the board.
- Para. 4.6.15 (c) Depth of immersion: Immerse the leads to the bottom surface of the board.
- Para. 4.6.15 (e) Duration of immersion:  $5 \pm 1$  seconds.

- 4.18 Moisture resistance (see 3.15). Thermistors shall be tested in accordance with para. 4.8.16 of MIL-PRF-23648.
- 4.19 High temperature exposure (see 3.16). Thermistors shall be tested in accordance with para. 4.8.18 of MIL-PRF-23648.
- 4.20 Vibration, high frequency (see 3.17). Thermistors shall be tested in accordance with para. 4.8.19 of MIL-PRF-23648.
- 4.21 Shock, specified pulse (see 3.18). Thermistors shall be tested in accordance with para. 4.8.20 of MIL-PRF-23648.
- 4.22 Immersion (see 3.19). Thermistors shall be tested in accordance with para. 4.8.21 of MIL-PRF-23648.
5. PREPARATION FOR DELIVERY
- 5.1 Preparation for delivery. Preparation for delivery shall be as specified in paragraph 5 of MIL-T-23468.
6. NOTES
- 6.1 WARNING. Use heat sinks when soldering or welding thermistor leads.
- 6.2 QCI data. A copy of the Group A variables data for the serialized thermistors shall accompany each shipment manufactured to this specification.
- 6.3 Ordering data. Acquisition documents should specify the following:
- a. Number, title, and date of this specification
  - b. Goddard Part Number
  - c. Quantity
- 6.4 Qualification provisions. With respect to product requiring qualification, awards will be made only for product which have been tested and approved by GSFC before the time for opening of bids. The attention of the suppliers is called to the following requirement: manufacturers should arrange to have qualification tests made on product which they propose to offer to GSFC to become eligible for awards of contracts or orders for product covered by this specification. The manufacturer shall bear the cost of qualification inspection to this specification. Information pertaining to qualification of product may be obtained from the activity whose address is listed in 4.4.1.

6.5 NOTICE. When GSFC drawings, specifications, or other data are sent for any purpose other than in connection with a definitely related GSFC procurement operation, the United States Government thereby incurs no responsibility nor any obligation whatsoever. The fact that GSFC might have formulated, furnished or in any way supplied the said drawings, specifications, or other data is not to be regarded by implication or otherwise as in any manner licensing the holder or any person or corporation, or conveying any right or permission to manufacture, use, or sell any patented invention that may in any way be related thereto.

Custodian:  
QPLD Administrator, Code 562  
Goddard Space Flight Center  
Greenbelt, MD 20771

Table V. Thermistor resistance versus temperature.

Dash No.	01	03	05	07	09
	02	04	06	08	10
$\Omega$ @ 25°C	2252	3000	5000	10,000	30,000
Temp. (°C)	Resistance $\Omega$				
-80	1660K	2211K	3685K	3558K	
79	1518K	2022K	3371K	3296K	
78	1390K	1851K	3086K	3055K	
77	1273K	1696K	2827K	2833K	
76	1167K	1555K	2592K	2629K	
75	1071K	1426K	2378K	2440K	
74	982.8K	1309K	2182K	2266K	
73	902.7K	1202K	2005K	2106K	
72	829.7K	1105K	1843K	1957K	
71	763.1K	1016K	1695K	1821K	
-70	702.3K	935.4K	1560K	1694K	
69	646.7K	861.4K	1436K	1577K	
68	595.9K	793.7K	1323K	1469K	
67	549.4K	731.8K	1220K	1369K	
66	506.9K	675.2K	1126K	1276K	
65	467.9K	623.3K	1039K	1190K	
64	432.2K	575.7K	959.9K	1111K	
63	399.5K	532.1K	887.2K	1037K	
62	369.4K	492.1K	820.5K	968.4K	
61	341.8K	455.3K	759.2K	904.9K	
-60	316.5K	421.5K	702.9K	845.9K	
59	293.2K	390.5K	651.1K	791.1K	
58	271.7K	361.9K	603.5K	740.2K	
57	252.0K	335.7K	559.7K	692.8K	
56	233.8K	311.5K	519.4K	648.8K	
55	217.1K	289.2K	482.2K	607.8K	
54	201.7K	268.6K	447.9K	569.6K	
53	187.4K	249.7K	416.3K	534.1K	
52	174.3K	232.2K	387.1K	501.0K	
51	162.2K	216.0K	360.2K	470.1K	
-50	151.0K	201.1K	335.3K	441.3K	
49	140.6K	187.3K	312.3K	414.5K	
48	131.0K	174.5K	291.0K	389.4K	
47	122.1K	162.7K	271.3K	366.0K	
46	113.9K	151.7K	253.0K	344.1K	
45	106.3K	141.6K	236.2K	323.7K	
44	99.26K	132.2K	220.5K	304.6K	
43	92.72K	123.5K	205.9K	286.7K	
42	86.65K	115.4K	192.5K	270.0K	
41	81.02K	107.9K	180.0K	254.4K	
-40	75.79K	101.0K	168.3K	239.8K	884.6K
39	70.93K	94.48K	157.5K	226.0K	830.9K
38	66.41K	88.46K	147.5K	213.2K	780.8K
37	62.21K	82.87K	138.2K	201.1K	733.9K
36	58.30K	77.66K	129.5K	189.8K	690.2K
35	54.66K	72.81K	121.4K	179.2K	649.3K
34	51.27K	68.30K	113.9K	169.3K	611.0K
33	48.11K	64.09K	106.9K	160.0K	575.2K
32	45.17K	60.17K	100.3K	151.2K	541.7K
31	42.42K	56.51K	94.22K	143.0K	510.4K
-30	39.86K	53.10K	88.53K	135.2K	481.0K
29	37.47K	49.91K	83.22K	127.9K	453.5K
28	35.24K	46.94K	78.26K	121.1K	427.7K
27	33.15K	44.16K	73.62K	114.6K	403.5K
26	31.20K	41.56K	69.29K	108.6K	380.9K
25	29.38K	39.13K	65.24K	102.9K	359.6K
24	27.67K	36.86K	61.45K	97.49K	339.6K
23	26.07K	34.73K	57.90K	92.43K	320.9K
22	24.58K	32.74K	54.58K	87.66K	303.3K
21	23.18K	30.87K	51.47K	83.16K	286.7K

Table V. Thermistor resistance versus temperature (continued).

Dash No.	01	03	05	07	09
	02	04	06	08	10
$\Omega$ @ 25°C	2252	3000	5000	10,000	30,000
Temp. (°C)	Resistance $\Omega$				
-20	21.87K	29.13K	48.56K	78.91K	271.2K
19	20.64K	27.49K	45.83K	74.91K	256.5K
18	19.48K	25.95K	43.27K	71.13K	242.8K
17	18.40K	24.51K	40.86K	67.57K	229.8K
16	17.39K	23.16K	38.61K	64.20K	217.6K
15	16.43K	21.89K	36.49K	61.02K	206.2K
14	15.54K	20.70K	34.50K	58.01K	195.4K
13	14.70K	19.58K	32.63K	55.17K	185.2K
12	13.91K	18.52K	30.88K	52.48K	175.6K
11	13.16K	17.53K	29.23K	49.94K	166.6K
-10	12.46K	16.60K	27.67K	47.54K	158.0K
9	11.81K	15.72K	26.21K	45.27K	150.0K
8	11.19K	14.90K	24.83K	43.11K	142.4K
7	10.60K	14.12K	23.54K	41.07K	135.2K
6	10.05K	13.39K	22.32K	39.14K	128.5K
5	9534	12.70K	21.17K	37.31K	122.1K
4	9046	12.05K	20.08K	35.57K	116.0K
3	8586	11.44K	19.06K	33.93K	110.3K
2	8151	10.86K	18.10K	32.37K	104.9K
-1	7741	10.31K	17.19K	30.89K	99.80K
0	7355	9796	16.33K	29.49K	94.98K
+1	6989	9310	15.52K	28.15K	90.41K
2	6644	8851	14.75K	26.89K	86.09K
3	6319	8417	14.03K	25.69K	81.99K°
4	6011	8006	13.34K	24.55K	78.11K
5	5719	7618	12.70K	23.46K	74.44K
6	5444	7252	12.09K	22.43K	70.96K
7	5183	6905	11.51K	21.45K	67.66K
8	4937	6576	10.96K	20.52K	64.53K
9	4703	6265	10.44K	19.63K	61.56K
+10	4482	5971	9951	18.79K	58.75K
11	4273	5692	9486	17.98K	56.07K
12	4074	5427	9046	17.22K	53.54K
13	3886	5177	8628	16.49K	51.13K
14	3708	4939	8232	15.79K	48.84K
15	3539	4714	7857	15.13K	46.67K
16	3378	4500	7500	14.50K	44.60K
17	3226	4297	7162	13.90K	42.64K
18	3081	4105	6841	13.33K	40.77K
19	2944	3922	6536	12.79K	38.99K
+20	2814	3748	6247	12.26K	37.30K
21	2690	3583	5972	11.77K	35.70K
22	2572	3426	5710	11.29K	34.17K
23	2460	3277	5462	10.84K	32.71K
24	2354	3135	5225	10.41K	31.32K
25	2252	3000	5000	10.00K	30.00K
26	2156	2872	4787	9605	28.74K
27	2064	2750	4583	9227	27.54K
28	1977	2633	4389	8867	26.40K
29	1894	2523	4204	8523	25.31K
+30	1815	2417	4029	8194	24.27K
31	1739	2317	3861	7880	23.28K
32	1667	2221	3702	7579	22.33K
33	1599	2130	3549	7291	21.43K
34	1533	2042	3404	7016	20.57K
35	1471	1959	3266	6752	19.74K
36	1412	1880	3134	6500	18.96K
37	1355	1805	3008	6258	18.21K
38	1301	1733	2883	6026	17.49K
39	1249	1664	2773	5805	16.80K

Table V. Thermistor resistance versus temperature (continued).

Dash No.	01	03	05	07	09
	02	04	06	08	10
$\Omega$ @ 25°C	2252	3000	5000	10,000	30,000
Temp. (°C)	Resistance $\Omega$				
+40	1200	1598	2663	5592	16.15K
41	1152	1535	2559	5389	15.52K
42	1107	1475	2459	5193	14.92K
43	1064	1418	2363	5006	14.35K
44	1023	1363	2272	4827	13.80K
45	983.8	1310	2184	4655	13.28K
46	946.2	1260	2101	4489	12.77K
47	910.2	1212	2021	4331	12.29K
48	875.8	1167	1944	4179	11.83K
49	842.8	1123	1871	4033	11.39K
+50	811.3	1081	1801	3893	10.97K
51	781.1	1040	1734	3758	10.57K
52	752.2	1002	1670	3629	10.18K
53	724.5	965.0	1608	3504	9807
54	697.9	929.6	1549	3385	9450
55	672.5	895.8	1493	3270	9109
56	648.1	863.3	1439	3160	8781
57	624.8	832.2	1387	3054	8467
58	602.4	802.3	1337	2952	8166
59	580.9	773.7	1290	2854	7876
+60	560.3	746.3	1244	2760	7599
61	540.5	719.9	1200	2669	7332
62	521.5	694.7	1158	2582	7076
63	503.3	670.4	1117	2497	6830
64	485.8	647.1	1079	2417	6594
65	469.0	624.7	1041	2339	6367
66	452.9	603.3	1006	2264	6149
67	437.4	582.6	971.1	2191	5940
68	422.5	562.8	938.0	2122	5738
69	408.2	543.7	906.3	2055	5545
+70	394.5	525.4	875.7	1990	5359
71	381.2	507.8	846.4	1928	5180
72	368.5	490.9	818.3	1868	5007
73	356.2	474.7	791.2	1810	4842
74	344.5	459.0	765.1	1754	4682
75	333.1	444.0	740.0	1700	4529
76	322.3	429.5	715.9	1648	4381
77	311.8	415.6	692.7	1598	4239
78	301.7	402.2	670.3	1549	4102
79	292.0	389.3	648.8	1503	3970
+80	282.7	376.9	628.1	1458	3843
81	273.7	364.9	608.2	1414	3720
82	265.0	353.4	588.9	1372	3602
83	256.7	342.2	570.4	1332	3489
84	248.6	331.5	552.6	1293	3379
85	240.9	321.2	535.4	1255	3273
86	233.4	311.3	518.8	1218	3172
87	226.2	301.7	502.8	1183	3073
88	219.3	292.4	487.4	1149	2979
89	212.6	283.5	472.6	1116	2887
+90	206.1	274.9	458.2	1084	2799
91	199.9	266.6	444.4	1053	2714
92	193.9	258.6	431.0	1023	2632
93	188.1	250.9	418.2	994.2	2552
94	182.5	243.4	405.7	966.3	2476
95	177.1	236.2	393.7	939.3	2402
96	171.9	229.3	382.1	913.2	2331
97	166.9	222.6	370.9	887.9	2262
98	162.0	216.1	360.1	863.4	2195
99	157.3	209.8	349.7	839.7	2131

Table V. Thermistor resistance versus temperature (continued).

Dash No.	01	03	05	07	09
	02	04	06	08	10
$\Omega$ @ 25°C	2252	3000	5000	10,000	30,000
Temp. (°C)	Resistance $\Omega$				
+100	152.8	203.8	339.6	816.8	2069
101	148.4	197.9	329.8	794.6	2009
102	144.2	192.2	320.4	773.1	1950
103	140.1	186.8	311.3	752.3	1894
104	136.1	181.5	302.5	732.1	1840
105	132.3	176.4	294.0	712.6	1788
106	128.6	171.4	285.7	693.6	1737
107	125.0	166.7	277.8	675.3	1688
108	121.6	162.0	270.1	657.5	1640
109	118.2	157.6	262.6	640.3	1594
+110	115.0	153.2	255.4	623.5	1550
111	111.8	149.0	248.4	607.3	1507
112	108.8	145.0	241.6	591.6	1465
113	105.8	141.1	235.1	576.4	1425
114	103.0	137.2	228.7	561.6	1386
115	100.2	133.6	222.6	547.3	1348
116	97.6	130.0	216.7	533.4	1311
117	95.0	126.5	210.9	519.9	1276
118	92.5	123.2	205.3	506.8	1241
119	90.0	119.9	199.9	494.1	1208
+120	87.7	116.8	194.7	481.8	1176
121	85.4	113.8	189.6	469.8	1145
122	83.2	110.8	184.7	458.2	1114
123	81.1	107.9	179.9	446.9	1085
124	79.0	105.2	175.3	435.9	1057
125	77.0	102.5	170.8	425.3	1029
126	75.0	99.9	166.4	414.9	1002
127	73.1	97.3	162.2	404.9	976.3
128	71.3	94.9	158.1	395.1	951.1
129	69.5	92.5	154.1	385.6	926.7
+130	67.8	90.2	150.3	376.4	903.0
131	66.1	87.9	146.5	367.4	880.0
132	64.4	85.7	142.9	358.7	857.7
133	62.9	83.6	139.4	350.3	836.1
134	61.3	81.6	136.0	342.0	815.0
135	59.8	79.6	132.6	334.0	794.6
136	58.4	77.6	129.4	326.3	774.8
137	57.0	75.8	126.3	318.7	755.6
138	55.6	73.9	123.2	311.3	736.9
139	54.3	72.2	120.3	304.2	718.8
+140	53.0	70.4	117.4	297.2	701.2
141	51.7	68.8	114.6	290.4	684.1
142	50.5	67.1	111.9	283.8	667.5
143	49.3	65.5	109.2	277.4	651.3
144	48.2	64.0	106.7	271.2	635.6
145	47.0	62.5	104.2	265.1	620.3
146	45.9	61.0	101.8	259.2	605.5
147	44.9	59.6	99.40	253.4	591.1
148	43.8	58.3	97.10	247.8	577.1
149	42.8	56.9	94.87	242.3	563.5
+150	41.9	55.6	92.70	237.0	550.2



Figure 2. Resistance tolerance curves (Page 1 of 2).

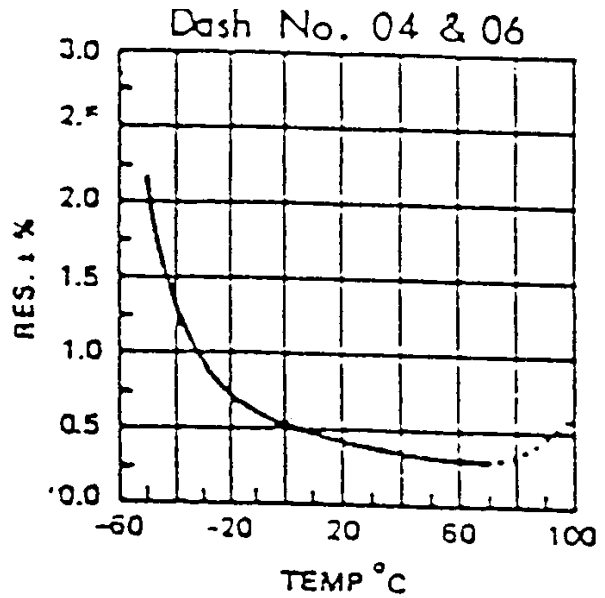
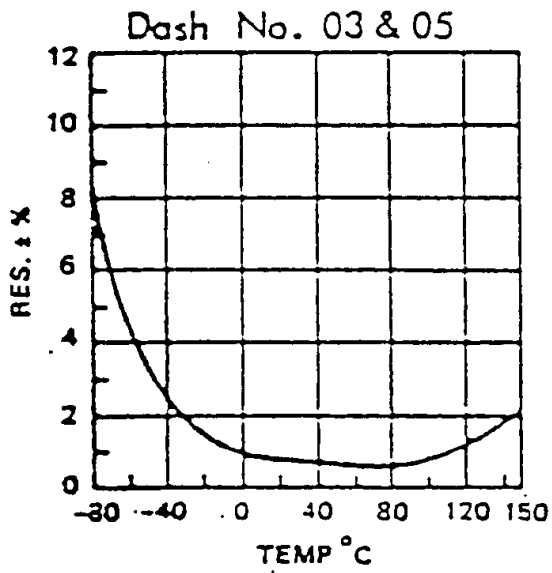
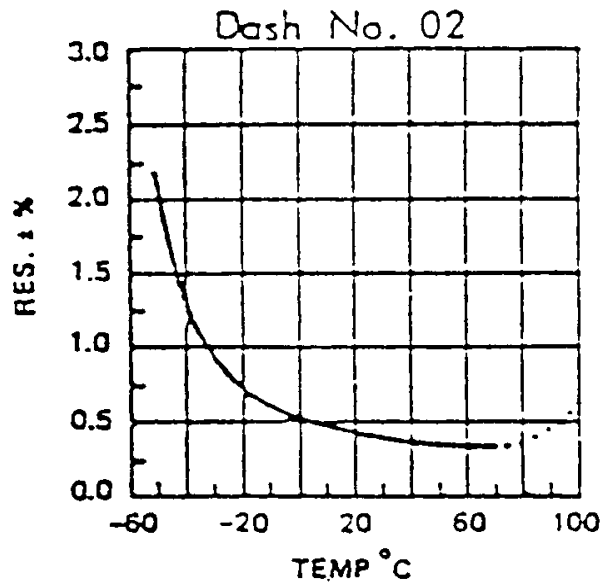
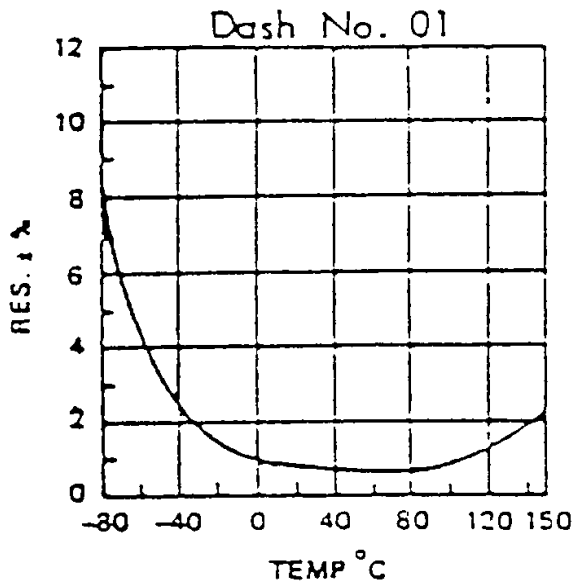

Figure 2. Resistance tolerance curves (Page 2 of 2).

